



# **Electronic 790 Refrigerator / Freezer**

## **Model**

E521TRX G FP SX 13

## **Product Code**

21651-C





## PRODUCT

<b>Brand</b>	Fisher & Paykel
<b>Voltage</b>	220-240V 50Hz
<b>Model</b>	E521TRX G FP SX 13
<b>Product Code</b>	21651-C

**Fisher & Paykel Appliances Ltd**  
78 Springs Road, East Tamaki  
PO Box 58-732, Greenmount  
Auckland, New Zealand  
Telephone: 09 273 0600  
Facsimile: 09 273 0656

**Fisher & Paykel Australia Pty Ltd**  
A.C.N. 003 335 171  
19 Enterprise Street  
P O Box 798  
Cleveland, Queensland 4163  
Telephone: 07 3826 9100  
Facsimile: 07 3826 9164

**Fisher & Paykel Appliances Ltd U.K**  
Pheasant Oak Barn,  
Hob Lane, Balsall Common  
Warwickshire, CV7 7GX  
England  
Telephone: +44 1676 531 770  
Facsimile: +44 1676 531 771



# CONTENTS

DOORS.....	6
CABINET COMPONENTS .....	8
FAN, COVERS AND EVAPORATOR ASSEMBLIES.....	12
DISPLAY MODULE AND DUCT COVERS .....	14
ACTIVE SMART ST4 TERMINALS PLUGS & SOCKETS.....	16
COMPRESSOR, ANCILLARY COMPONENTS & CONTROL MODULE.....	18
NOTES .....	22
REFRIGERATION ABBREVIATION KEY .....	23

## GUIDE TO USING THIS MANUAL

The model covered by this manual is listed on the front cover.

The information detailed in this manual is subject to change without notice, the latest version is indicated by the reprint date and replaces any earlier editions.

The front cover picture shows the type of product and may not necessarily be an exact image of the models covered by the manual.

### Kit Parts

The components shown in *italics with a part number* are those parts in the kit which are available also as separate items. In addition, some parts may be supplied with this kit which are not available as separate items and are therefore either not listed or a part number is not shown against the part description in this manual.

All details relating to Technical Bulletins or Notes are shown on a dedicated page. The Technical Bulletin Number shown relates to the bulletin version which is produced for the Global Service Centres.

### Parts List Key

NOT USED	As a part, indicates the diagram part reference is not used in this manual.
#	Beside the part number, indicates the part is no longer available.
<i>italics</i>	Kit components or parts included are shown in <i>italics</i> , refer to above notes: Kit Parts
*	Indicates a Technical Bulletin or note exists for the part or part reference.
NI	As a part reference, indicates the part is not illustrated on the diagram.

# DOORS

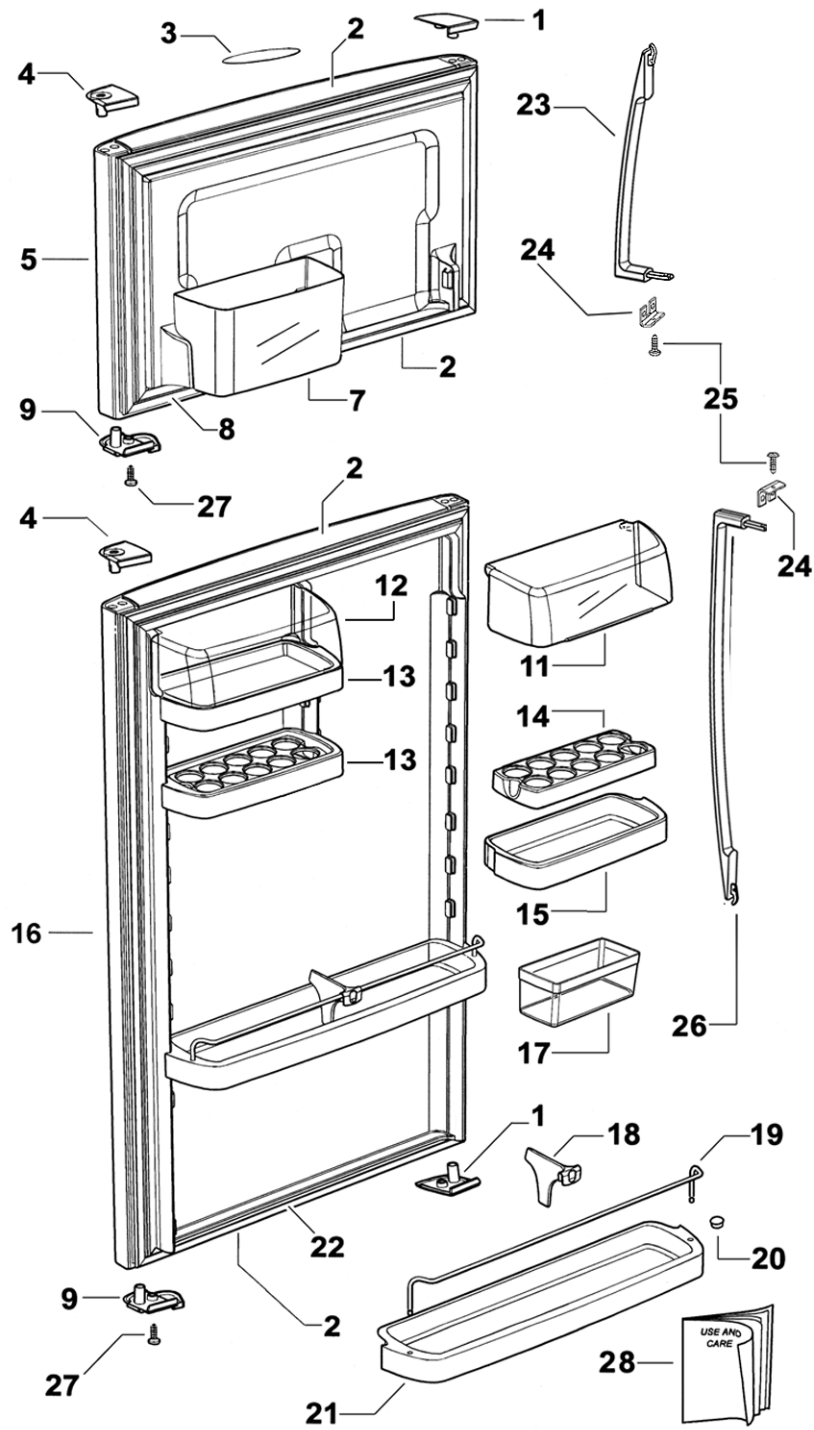

## DOORS

REF	PART	DESCRIPTION
1	883981	COVER HGE DR RHT/LHB SILVER 680/790
	883982	COVER HGE DR LHT/RHB SILVER 680/790
2	883974	CAP DOOR END OUTER SILVER 790
3	NOT USED	
4	883996	BEARING HINGE RH SILVER 680/790
5	312154P	DOOR FC SZ 790X 443 RT CS E521T
7	882378	BIN FC 790
8	883736P	GASKET ASSY E521T FC LGREY
9	883979	BEARING DR CLOSE RH GY 680/790
11	882141	COVER DOOR SHELF RH
12	882140	COVER COMP 790 LH
13	882145	SHELF DOOR SML LH 790
14	882323	SHELF EGG RACK
15	882146	SHELF DOOR SML RH 790
16	309032P	DOOR PC G SZ 790X1200 RH
17	871129	BIN EGG/ICE MOULD
18	883121	DIVIDER BOTTLE RAIL WHITE
19	881357	RAIL BOTTLE SUPPORT SATIN CHROME 790
20	876281	PLUG DOOR SHELF WHITE
21	882100	SHELF DOOR LARGE 790
22	883735P	GASKET ASSY E521T PC LGREY
23	884571	HANDLE DOOR CURVED SHORT
24	881391	PLATE HANDLE SUPPORT PLATED
25	881044P	SCREW 8X22 WAFER PHIL STZP (PKT 10)
26	884570	HANDLE DOOR CURVED LONG
27	881044P	SCREW 8X22 WAFER PHIL STZP (PKT 10)
28	884466	BOOKLET USE & CARE FRIDGE EU

# CABINET COMPONENTS

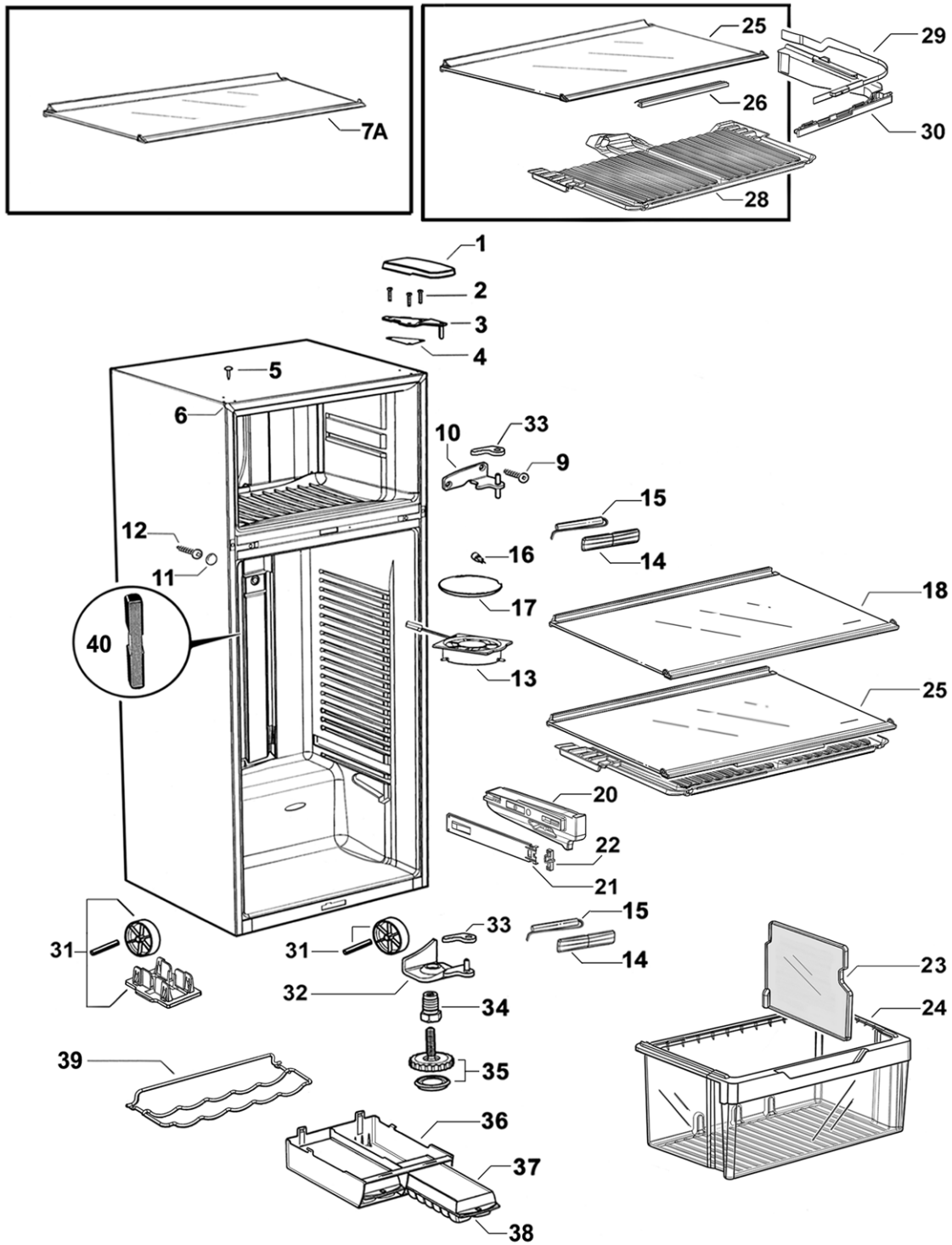



## CABINET COMPONENTS

REF	PART	DESCRIPTION
1	883990	COVER TOP HINGE SILVER
2	SP0282P	SCREW MC M5X20 HEX PH MS ZNPL (PKT 10)
3	880526	BRACKET TOP HINGE ASSY
4	882355	GASKET TOP HINGE
5	883948	PLUG TAPPED HOLE SILVER
6	883951	TRIM CORNER RECESSED SILVER
7A	836754	SHELF GLASS FC 790T ASSY SC
	<i>Includes 836569</i>	<i>PLUG STIFFENER SHELF RH</i>
	<i>Includes 836570</i>	<i>PLUG STIFFENER SHELF LH</i>
	<i>Includes 836567</i>	<i>PLUG TRIM SHELF RH</i>
	<i>Includes 836568</i>	<i>PLUG TRIM SHELF LH</i>
	<i>Includes</i>	<i>TRIM SHELF FC 790 SC</i>
	<i>Includes</i>	<i>STIFFENER SHELF FC 790 SC</i>
	<i>Includes</i>	<i>SHELF GLASS FC 790</i>
9	880656P	SCREW 10GX25CSK SQ SS (PKT 10)
10	881283	BRACKET CENTRE HINGE RH
11	883953	CAP SCREW CROSS RAIL SILVER
12	880655P	SCREW #10X19 AB #2 SQ ZN NP (PKT 10)
13	884518P	FAN & HOUSING PC ASSY
	<i>Includes</i>	<i>CONNECTOR IDC UP2 (2)</i>
	<i>Includes</i>	<i>LABEL WARNING 12 VOLT DC</i>
	<i>Includes</i>	<i>FAN &amp; HOUSING PC ASSY</i>
NI	875110	GASKET INSULATION FAN PC
14	884011	COVER REED SWITCH ST4 SILVER
15	881223P	SWITCH REED FIELD FIX KIT ST4
16	874017	LAMP HALOGEN PC
17	875318	COVER LAMP PC
18	836751	SHELF GLASS PC 790 ASSY SC
	<i>Includes 836569</i>	<i>PLUG STIFFENER SHELF RH</i>
	<i>Includes 836570</i>	<i>PLUG STIFFENER SHELF LH</i>
	<i>Includes 836567</i>	<i>PLUG TRIM SHELF RH</i>
	<i>Includes 836568</i>	<i>PLUG TRIM SHELF LH</i>
	<i>Includes</i>	<i>TRIM SHELF PC 790 SC</i>
	<i>Includes</i>	<i>STIFFENER SHELF PC 790 SC</i>
	<i>Includes</i>	<i>SHELF GLASS PC 790</i>
20	836543	RETAINER SLIDE PC T RH
	836544	RETAINER SLIDE PC T LH
21	836700	SLIDE 300 RH ASSEMBLY
	<i>Includes 836520</i>	<i>CLIP SLIDE</i>
	836701	SLIDE 300 LH ASSEMBLY
	<i>Includes 836520</i>	<i>CLIP SLIDE</i>
22	836520P	CLIP SLIDE (PKT 2)
23	836533	DIVIDER BIN LARGE
24	836661	BIN ASSEMBLY LARGE 790
	<i>Includes</i>	<i>HANDLE BIN LARGE</i>

Continued next page

# CABINET COMPONENTS

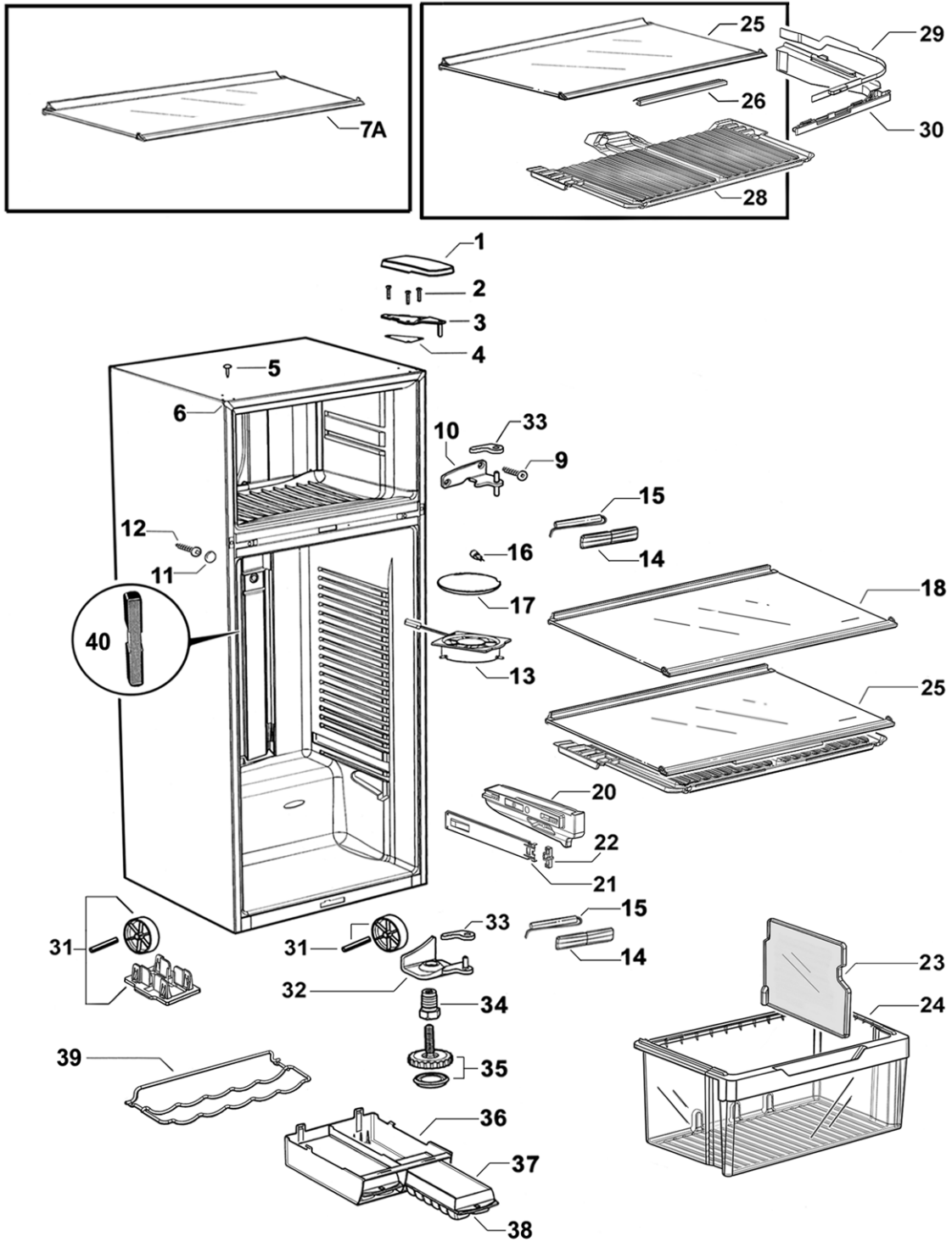

## CABINET COMPONENTS

REF	PART	DESCRIPTION
25	836757	SHELF GLASS HCL 790T ASSY SC
	<i>Includes 836569</i>	<i>PLUG STIFFENER SHELF RH</i>
	<i>Includes 836570</i>	<i>PLUG STIFFENER SHELF LH</i>
	<i>Includes 836567</i>	<i>PLUG TRIM SHELF RH</i>
	<i>Includes 836568</i>	<i>PLUG TRIM SHELF LH</i>
	<i>Includes</i>	<i>TRIM SHELF HCL 790 SC</i>
	<i>Includes</i>	<i>STIFFENER SHELF PC 790 SC</i>
	<i>Includes</i>	<i>SHELF GLASS HCL T 790</i>
26	836582	RETAINER HCL FRONT 790
28	836578	LID HUMIDITY CONTROL 790T
29	836631	SLIDE CONTROL HUMIDITY RH
	836633	SLIDE CONTROL HUMIDITY LH
30	836632	GUIDE CONTROL HUMIDITY RH
	836634	GUIDE CONTROL HUMIDITY LH
31	315090P	KIT WHEEL BRACKET CLIP
	<i>Includes</i>	<i>PIN ROLLER PLATED</i>
	<i>Includes</i>	<i>ROLLER FOOT FRONT</i>
	<i>Includes</i>	<i>CLIP WHEEL BRACKET</i>
32	881274	BRACKET BTTM HINGE RH
33	883988	CAP DOOR CLOSING HGE BRKT GY RH
34	880959	BOLT BTTM HINGE BRKT
35	880512	FOOT LEVELLING ASSEMBLY
	<i>Includes</i>	<i>WHEEL LEVELLING FOOT ASSY 880514</i>
	<i>Includes</i>	<i>BASE LEVELLING FOOT 880519</i>
36	836596	TRAY ICE HOLDER
37	874108	TRAY ICE LID
38	874107	TRAY ICE BASE
39	884396P	RACK BOTTLE 790
40	NOT USED	
<b>JOINER KIT FOR SIDE BY SIDE CABINET CONNECTION</b>		
Used for combining any of the the following 1695mm high cabinet models: N388 ,C450, E402B, E411T, E415H, E440T, E442B, E521T and E522B		
NI	813690	KIT JOINER SILVER

## FAN, COVERS AND EVAPORATOR ASSEMBLIES

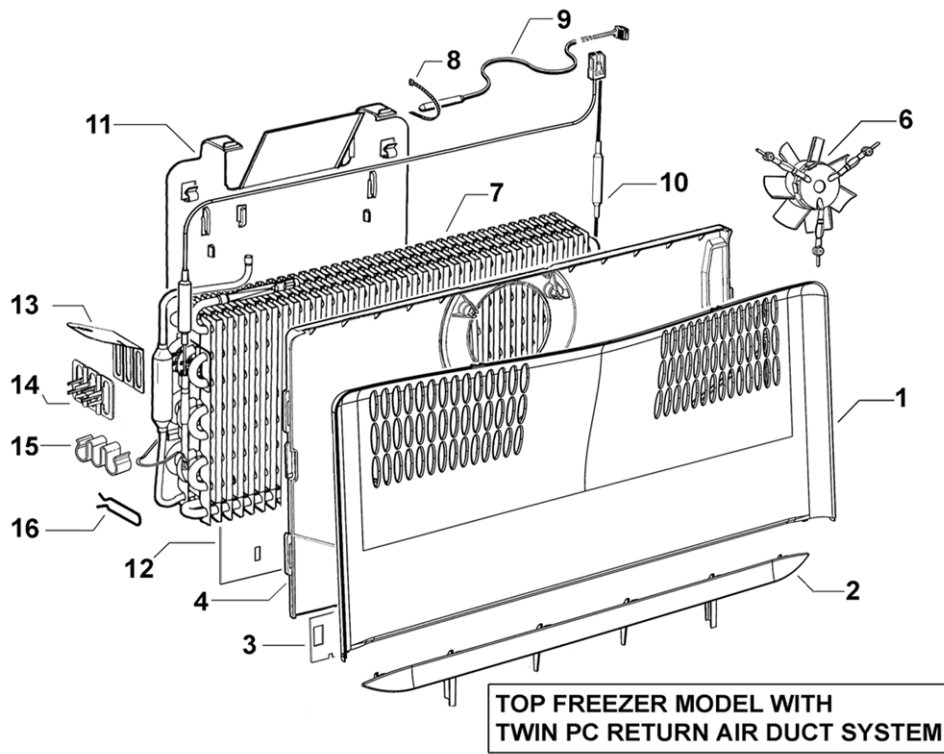

## FAN, COVERS & EVAPORATOR ASSEMBLIES

REF	PART	DESCRIPTION
1	883688	COVER FAN FC FRONT 790T
2	883693	COVER VENT 790T
3	883783	SHIELD FC REAR COVER
4		COVER FAN FC REAR 790 (Part of 306096P Kit)
	306096P	FAN FC KIT 790 SERIES A to C
	<i>Includes 880279</i>	<i>SHIELD HEATER FC COVER</i>
	<i>Includes</i>	<i>COVER FAN FC REAR 790</i>
	<i>Includes</i>	<i>CONNECTOR IDC IDC UP2 (2)</i>
	<i>Includes</i>	<i>LABEL WARNING 12 VOLT DC</i>
	<i>Includes</i>	<i>FAN DC SUSPENDED FC ASSY</i>
6		FAN DC SUSPENDED FC ASSY (Part of 306096P Kit)
7	881437P	EVAPORATOR SERV KIT 790 ST4.2 (DEFROST HEATER NOT INCLUDED)
	<i>Includes 883863</i>	<i>JOINER CAPILLARY</i>
	<i>Includes 883864</i>	<i>CAPILLARY SHORT 200MM</i>
	<i>Includes 855305</i>	<i>HARNESS ADAPTOR DFROST</i>
	<i>Includes 883349</i>	<i>CLIP DEFROST HEATER B MODEL EVAP (2)</i>
	<i>Includes 883350</i>	<i>CLIP DEFROST HEATER T MODEL EVAP</i>
8	900325	TIE PLASTIC 140MM
9	855203P	SENSOR KIT ASSY
	<i>Includes</i>	<i>HEATSHRINK 1/8" MW ADHESIVE LINED</i>
	<i>Includes</i>	<i>HARNESS SENSOR PC</i>
10	884125P	HEATER DEF & FUSE YELL LEAD 790 240V (EXTENDED HOT TAIL)
	<i>Includes 883349</i>	<i>CLIP DEFROST HEATER B EVAP (1)</i>
	<i>Includes 883350</i>	<i>CLIP HEATER DEFROST T EVAP (2)</i>
	<i>Includes 883756</i>	<i>LEAFLET INSTRUCTION 790B DEF HTR</i>
	<i>Includes 855305</i>	<i>HARNESS ADAPTOR DEFROST</i>
	<i>Includes 900325</i>	<i>TIE PLASTIC 140MM (2)</i>
11	880495	CHASSIS EVAP ELECT T MODEL
12	883792	SHIELD EVAP CHASS T MODEL
13	880724	DEFLECTOR AIR FLOW
14	871463	CLIP TUBE EVAP PLASTIC
15	883350	CLIP HEATER DEFROST T EVAP
16	855299	CLIP HEATER 20MM EVAP FIN (2)

# DISPLAY MODULE AND DUCT COVERS

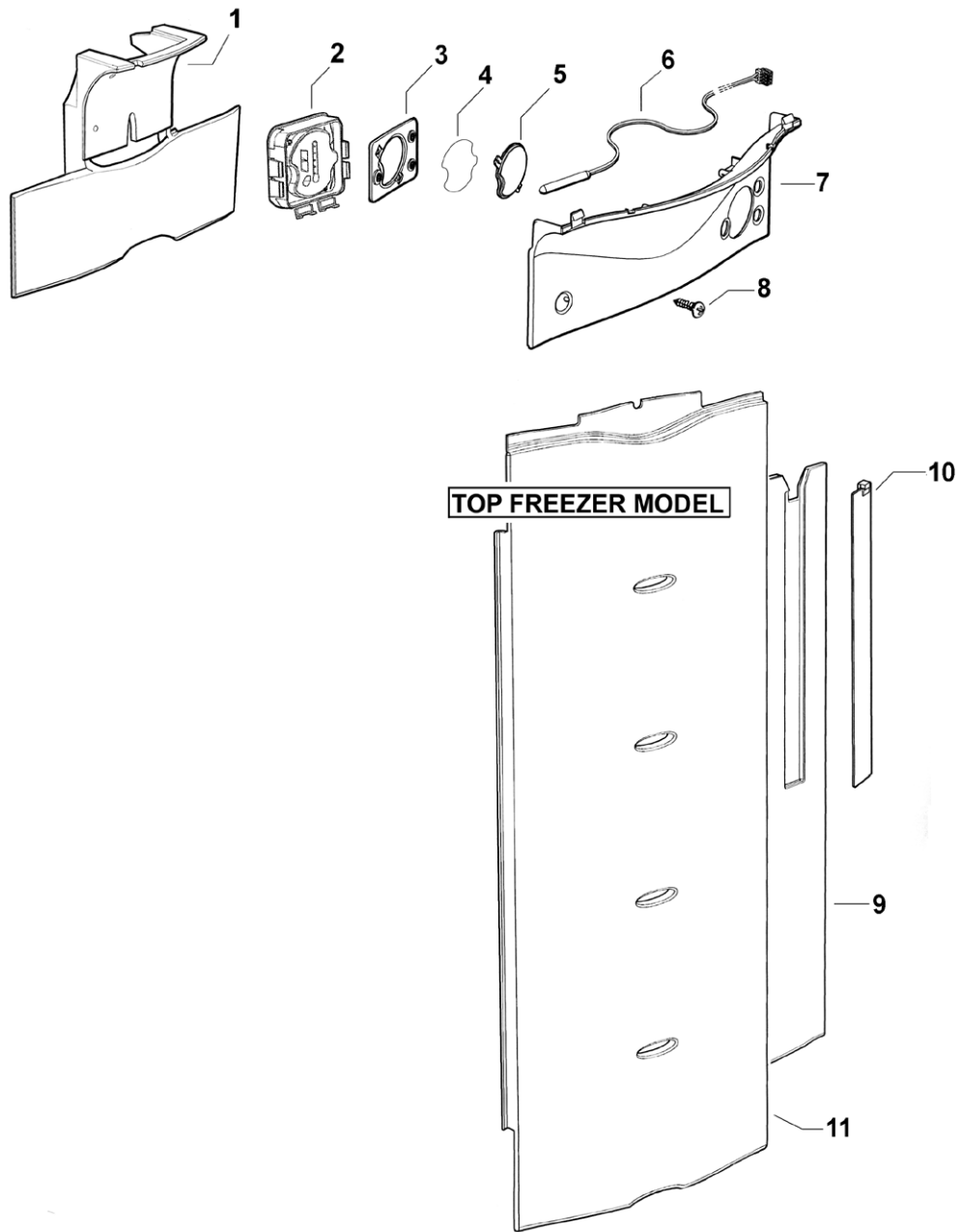

## DISPLAY MODULE AND DUCT COVERS

REF	PART	DESCRIPTION
1	880759	INSULATION COVER DUCT TOP T MOD
2	881218P	MODULE DISPLAY – BC ST4
3	880779	GASKET DISPLAY MODULE
4	883448	INSERT GRAPHICS DISPLAY
5	883449	LENS CLEAR-DISPLAY MODULE
6	855203P	SENSOR KIT ASSY
	<i>Includes</i>	<i>HEATSHRINK 1/8" MW ADHESIVE LINED</i>
	<i>Includes</i>	<i>HARNESS SENSOR PC</i>
7	836765	COVER DUCT TOP PC T
8	900475P	SCREW 8X16.4MM SP PAN NIB ST (PKT 10)
9	880259	INSULATION COVER DUCT LONG T
10	880571	HEATER PCB LOW AMB T MODELS
11	813534	COVER DUCT T MODEL LONG

# ACTIVE SMART ST4 TERMINALS PLUGS & SOCKETS

## ACTIVE SMART STAGE 4 TERMINALS, PLUGS AND SOCKETS

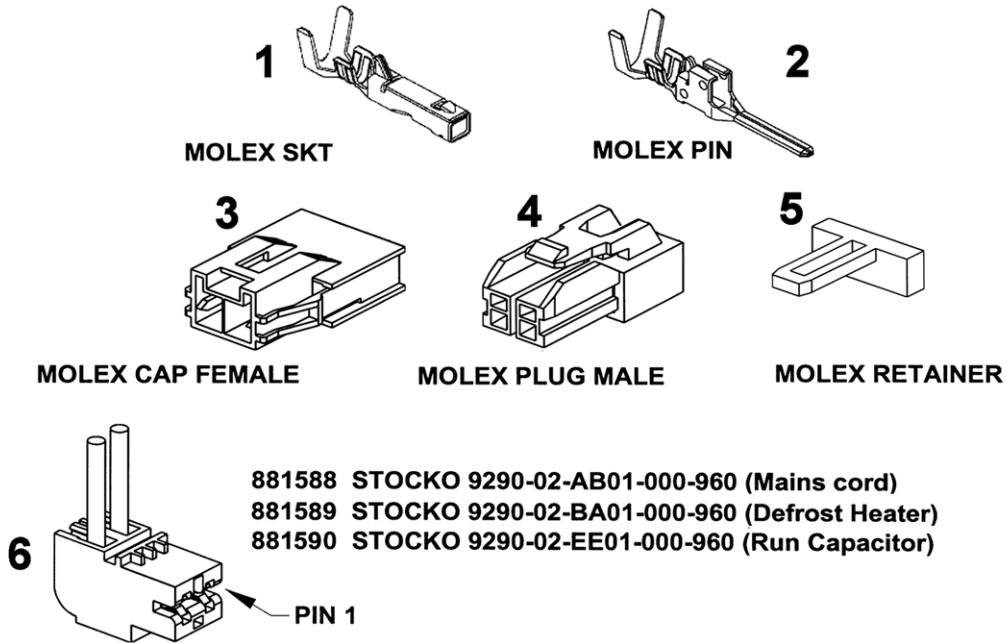

NOTE THAT IN THE PART NAMES OF THESE CONNECTORS, THE -02- REFERS TO IT BEING A 2 WAY CONNECTOR, AND THE -AB01- (FOR EXAMPLE) REFERS TO THE CODING OF THE CONNECTOR. STOCKO IS THE MANUFACTURER OF THESE CONNECTORS.

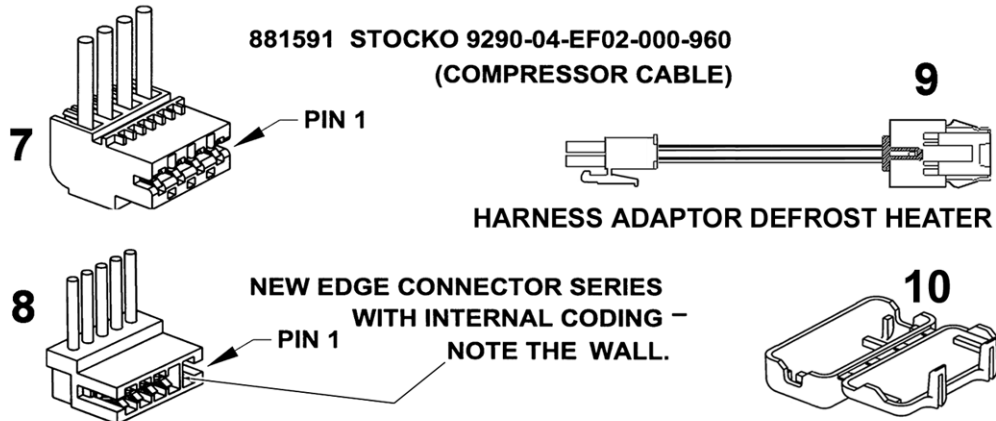

NOTE: TO MINIMISE THE NUMBER OF SPARE PARTS THAT NEED TO BE CARRIED, THESE CODED CONNECTORS ARE TO BE REPLACED WITH THEIR UN-CODED EQUIVALENTS. FOR THE 3, 5 AND 6 WAY CONNECTORS USED ON STAGE 4 CABINETS



## ACTIVE SMART ST4 TERMINALS PLUGS & SOCKETS

REF	PART	DESCRIPTION
1	881595	SOCKET 16-22AWG 50597-8100 MLX
	881596	SOCKET 20-26AWG 50598-8100 MLX
2	881597	PIN 16-22AWG 50599-8100 MLX
	881598	PIN 20-26AWG 50600-8100 MLX
3	881592	CAP FEMALE 51139-0200 MLX
4	881593	PLUG MALE 51138-0200 MLX
5	881594	RETAINER 51140-0205 MLX
6	881588	CONNECTOR RAST 9290-02-AB01
	881589	CONNECTOR RAST 9290-02-BA01
	881590	CONNECTOR RAST 9290-02-EE01
7	881591	CONNECTOR RAST 9290-04-EF02
8	873243	CONNECTOR RAST 7234-012-500
	873247	CONNECTOR RAST 7234-006-500
	873248	CONNECTOR RAST 7234-010-500
	873250	CONNECTOR RAST 7234-004-500
	873251	CONNECTOR RAST 7234-003-500
	873279	CONNECTOR RAST 7234-008-500
	881135	CONNECTOR RAST 7234-005-500
	881136	CONNECTOR RAST 7234-014-500
	881137	CONNECTOR RAST 7234-017-502
9	855305	HARNESS ADAPTOR DEFROST HEATER
10	884412	COVER PLUG MLX

NOTE: THE NUMBERS IN THE DESCRIPTION OF THE RAST CONNECTOR DENOTES THE NUMBER OF CONNECTIONS

EXAMPLE: 7234-017-502 =17 WAY CONNECTOR

# COMPRESSOR, ANCILLARY COMPONENTS & CONTROL MODULE

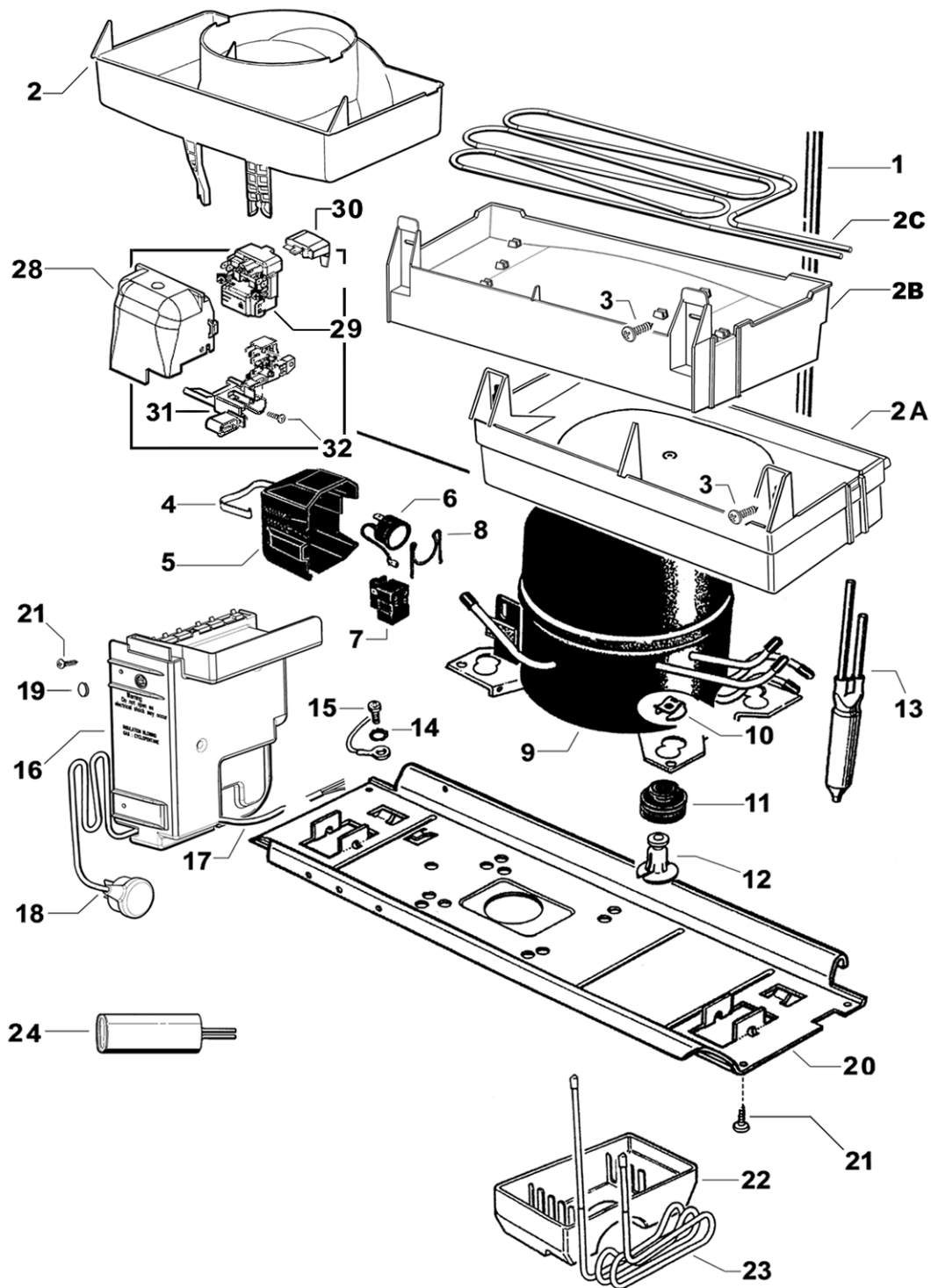

## COMPRESSOR, ANCILLARY COMPONENTS & CONTROL MODULE

REF	PART	DESCRIPTION
1	882137	PANEL BACK & CONDENSER ASSEMBLY
2	NOT USED	
2A	876652	TRAY WATER EVAPORATION MOULDED
2B	NOT USED	
2C	NOT USED	
3	SP0201P	SCREW 8X12 PAN PH NIB (PKT 10)
4	NOT USED	
5	NOT USED	
6	NOT USED	
7	NOT USED	
8	NOT USED	
9	207126P	COMPR MAT DGX86C15TAY 230-240V 50HZ
	<i>Includes 207131</i>	<i>RELAY PTC MAT M150MB3</i>
	<i>Includes 207143</i>	<i>O/LOAD MAT 734MFBYY DGX86</i>
	<i>Includes 207159</i>	<i>CAPACITOR RUN 2.5Uf 400VAC RAST5</i>
	▶ <i>Includes 207169</i>	<i>GROMMET COMPRESSOR MOUNTING 33M (4)</i>
	<i>Includes 207173</i>	<i>CAPACITOR START 45uf 400VAC (50mm x 116mm)</i>
	<i>Includes 207174</i>	<i>BRACKET HALF SADDLE 50mm</i>
	<i>Includes 209078</i>	<i>COVER PROTECTOR,</i>
	<i>Includes 209673</i>	<i>CLIP COVER 01-245233</i>
	<i>Includes 502173</i>	<i>FILTER DRIER 12 GR DUAL BRAZED</i>
	▶ <i>Includes 813421</i>	<i>PIN COMPRESSOR MOUNTING 33MM (4)</i>
	<i>Includes 813435</i>	<i>TRAY WATER EVAP TOP HAT</i>
	<i>Includes 813393</i>	<i>HARNESS COMPRESSOR 4 CORE DGX</i>
	<i>Includes 855270</i>	<i>CLIP FOOT COMPRESSOR</i>
	<i>Includes 883201</i>	<i>TUBE CU 4.76X155 DBLE SWAGE</i>
	<i>Includes 901525</i>	<i>SCREW #8X12 SP PAN NIB ST ZP (2)</i>
	<i>Includes 813773</i>	<i>INSTRUCTION SHEET DGX SERIES</i>
10	855270	CLIP FOOT COMPRESSOR
11	207169	GROMMET COMPRESSOR MOUNTING 33mm
12	813421	PIN COMPRESSOR MOUNTING 33mm
<b>▶ IMPORTANT:- MUST BE USED WITH MATSUSHITA DGX COMPRESSORS</b>		
13	502173P	FILTER DRIER 12 GR DUAL BRAZED
14	900101P	WASHER LOCK NO 10 EXT SP ZP (PKT 10)
15	900377P	SCREW 8X32X8 TYPE 23 PAN PH ZP (PKT 10)
16	884519P	MODULE CONTROL 220-240V ST4.2 SP KIT
	<i>Includes 813212</i>	<i>INSTRUCTION SHEET ST4.2 CONTL MODULE KIT</i>
	<i>Includes 813236</i>	<i>INSTRUCTION SHEET ST4.2 DIAGNOSTIC</i>
	<i>Includes 884518</i>	<i>FAN &amp; HOUSING PC ASSY (OVER MOULDED FAN)</i>
	<i>Includes</i>	<i>MODULE CONTROL 220-240V ST4.2</i>
17	813394	HARNESS COMPRESSOR 4 CORE EGZ
	813393	HARNESS COMPRESSOR 4 CORE DGX
18	881402	CABLE SUPPLY EUROPE ST4

Continued next page

# COMPRESSOR, ANCILLARY COMPONENTS & CONTROL MODULE

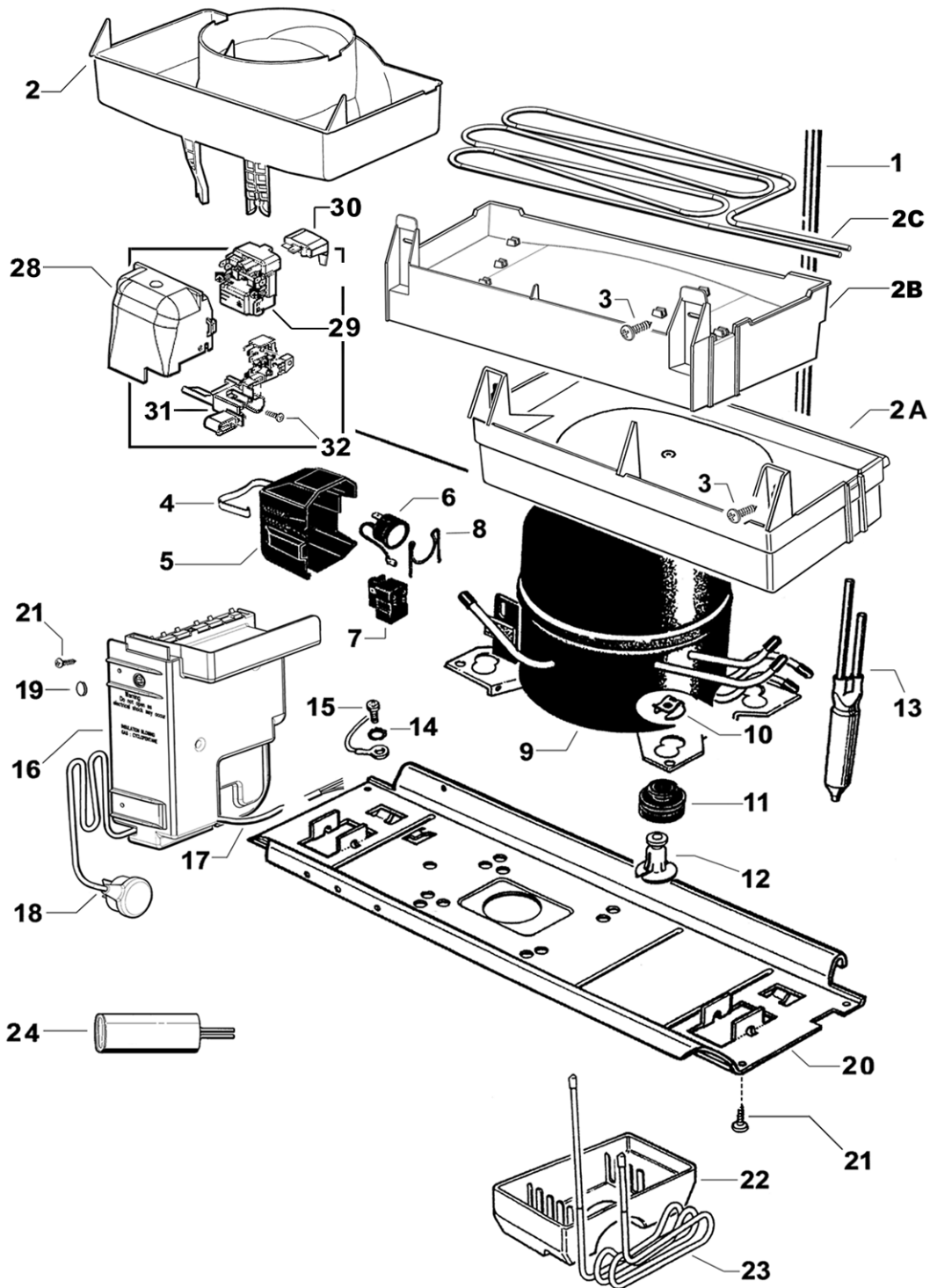

## COMPRESSOR, ANCILLARY COMPONENTS & CONTROL MODULE

REF	PART	DESCRIPTION
19	875861	PLUG PLASTIC LT GREY
20	878489	TRAY COMP MOUNTING 790
21	900475P	SCREW 8X16.4MM NIB STZP (PKT 10)
22	873228	TRAY WATER OVERFLOW
23	873040	TUBE HEATER SHEATHED 4.2MM
24	207161	CAPACITOR RUN 5Uf 400VAC RAST5 (30mm x 71mm) EMBRACO EGZ COMPRESSOR 220-240V 50Hz
28	209078	COVER PROTECTOR (DGX)
29	207156	RELAY TSD-O/LOAD EMB 213FPBYY EGZ90
	207131	RELAY PTC MAT 150MB3M24 DGX
30	207143	OVERLOAD MAT 734MFBYY DGX86
31	207168	CLAMP CORD EMB EGZ COMPR
32	207176	SCREW EMB CORD CLAMP (EGZ)
NI	874329	CABLE LEAD EARTH
NI	883922	SUCTION & CAPILLARY ASSY

## NOTES

## REFRIGERATION ABBREVIATION KEY

<b>10W</b>	<b>10 WATTS</b>
<b>12V</b>	<b>12 VOLTS</b>
<b>BC</b>	<b>BUTTER CONDITIONER</b>
<b>BS</b>	<b>“B” SERIES CABINET</b>
<b>CH</b>	<b>CHARCOAL COLOUR</b>
<b>DC</b>	<b>DIRECT CURRENT</b>
<b>DK GY</b>	<b>DARK GREY</b>
<b>F&amp;P</b>	<b>FISHER &amp; PAYKEL</b>
<b>FC</b>	<b>FREEZER COMPARTMENT</b>
<b>HAN P/C</b>	<b>HANDLE POWDER COATED</b>
<b>HC</b>	<b>HUMIDITY COMPARTMENT</b>
<b>HCL</b>	<b>HUMIDITY CONTROL LID</b>
<b>HS</b>	<b>HOT STAMPED</b>
<b>LH</b>	<b>LEFT HAND</b>
<b>LHB</b>	<b>LEFT HAND BOTTOM</b>
<b>LHT</b>	<b>LEFT HAND TOP</b>
<b>LT GY</b>	<b>LIGHT GREY</b>
<b>M5</b>	<b>5 MILLIMETER</b>
<b>MD GY</b>	<b>MID GREY</b>
<b>MEPS</b>	<b>MINIMUM ENERGY PERFORMANCE STANDARDS</b>
<b>PC</b>	<b>PROVISION COMPARTMENT</b>
<b>PUSHIN</b>	<b>PUSHIN TYPE GASKET</b>
<b>RH</b>	<b>RIGHT HAND</b>
<b>RHB</b>	<b>RIGHT HAND BOTTOM</b>
<b>RHT</b>	<b>RIGHT HAND TOP</b>
<b>SA or S/STONE</b>	<b>SANDSTONE COLOUR</b>
<b>SATIN OR SC</b>	<b>SATIN CHROME FINISH</b>
<b>SL or SIL</b>	<b>SILVER</b>
<b>SML</b>	<b>SMALL</b>
<b>SS</b>	<b>STAINLESS STEEL</b>
<b>X/RAIL</b>	<b>CROSS RAIL</b>
<b>XH9</b>	<b>TYPE OF DESSICANT WITHIN A FILTER DRIER</b>